

Submersible Dry-Pit Sewage Pump

Type DDL

APPLICATIONS

- Sewage
- Waste Water
- Storm water drainage

OPTIONS AVAILABLE

- Free standing type
- Q.D.C. type
- Dry-pit type

FEATURES

- Air filled, Class F insulated, heavy duty motor, dissipates heat easily, operates cooler with higher efficiencies; longer service life with lower operating costs.
- Built-in motor protection with autocut, protects motor against overheating and no load; saves money on costly motor replacement.
- Molded cable prevents capillary action; reduces maintenance costs.
- Heavy duty ensures long, dependable operation and lowers maintenance costs.
- Large solids handling capabilities prevents clogging.
- Semi-open impellers offer the best design for handling stringy and/or abrasive materials due to the large wear area and open passageways, providing durability and longer life.
- High quality stainless steel shaft; provides high tensile strength, corrosion resistance, longer life, and lower maintenance costs.
- Double mechanical seals - silicon carbide lower seals, carbon/ceramic upper - hard faced upper and lower seals operate in an oil bath; providing longer service life and lower maintenance costs.



PERFORMANCE CHART

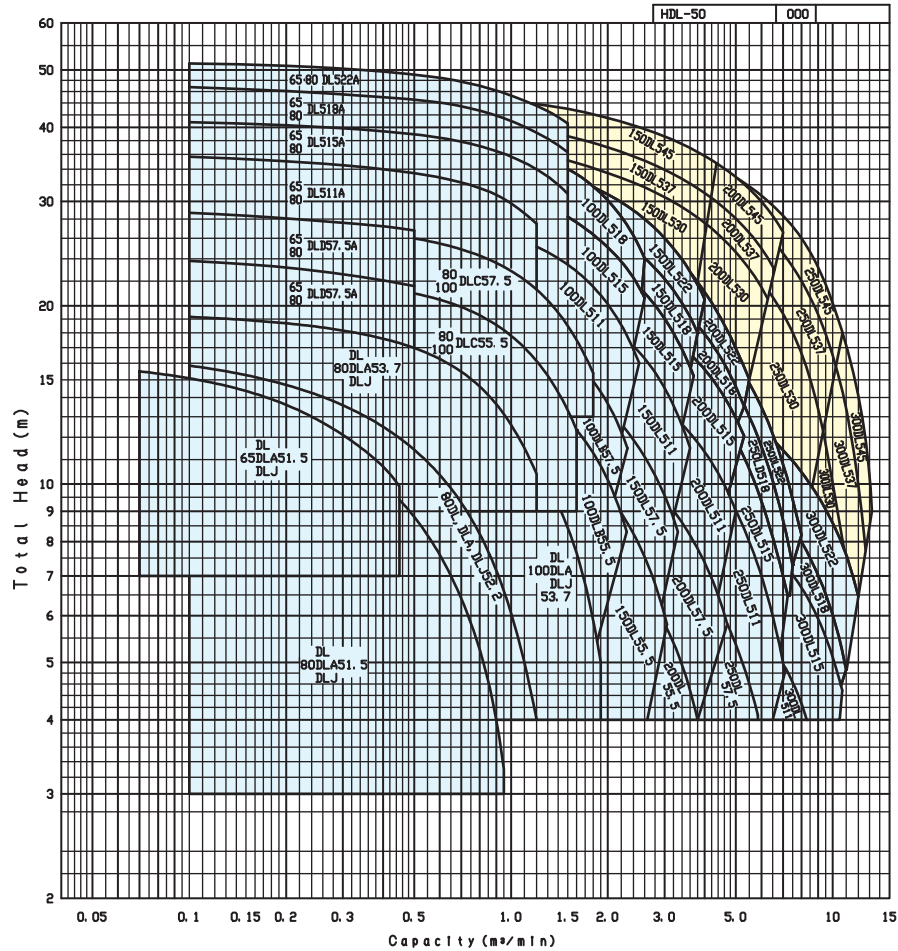

SPECIFICATIONS

		Standard	Optional
Scope	Discharge	65~300mm	
	Motor Power	1.5~45kW (3 phase)	
	Performance	Capacity : 0.07~13.2m³/min Head: 3~52m	
Liquid	Type	Sewage	
	Maximum temperature	40°C (Manual)	
Submergence	Maximum	8m	
Construction	Impeller	Non-clog semi-open	
	Mechanical Seal	Oil lubricated, double mechanical seal (single spring up to 3.7k W) (tandem spring 5.5 to 45kW)	
Materials	Casing	Cast Iron	
	Impeller	Cast Iron	
	Suction Cover	Cast Iron	
	Shaft	403 Stainless Steel	
	Motor Frame	Cast Iron	
	Fasteners	304 Stainless Steel	
	Mechanical Seal	Upper Faces : Carbon/Ceramic Lower Faces : Silicon Carbide/ Silicon Carbide Lubricating Oil : Turbine Oil VG32(SAE10W/20W)	
	Cooling Jacket	Mild Steel	
Motor	Type	Air filled dry submersible, IP68, Class F insulation	
	Nominal Speed	4 pole 1450rpm	
	Applicable Voltages	380/400/415 volts 3 phase 50 Hz	
	Starting	DOL (up to 2.2kW) Star Delta (3.7 to 45kW)	
	Protection	In built overload protection (up to 7.5kW) Miniature thermal protector (11 to 45kW)	
	Bearings	Pre lubricated sealed ball bearings	
Cable	Length	10m	
Accessories	Discharge connection, suction elbow, pump stand, cooling jacket		Cleaning Hole

SECTIONAL VIEW

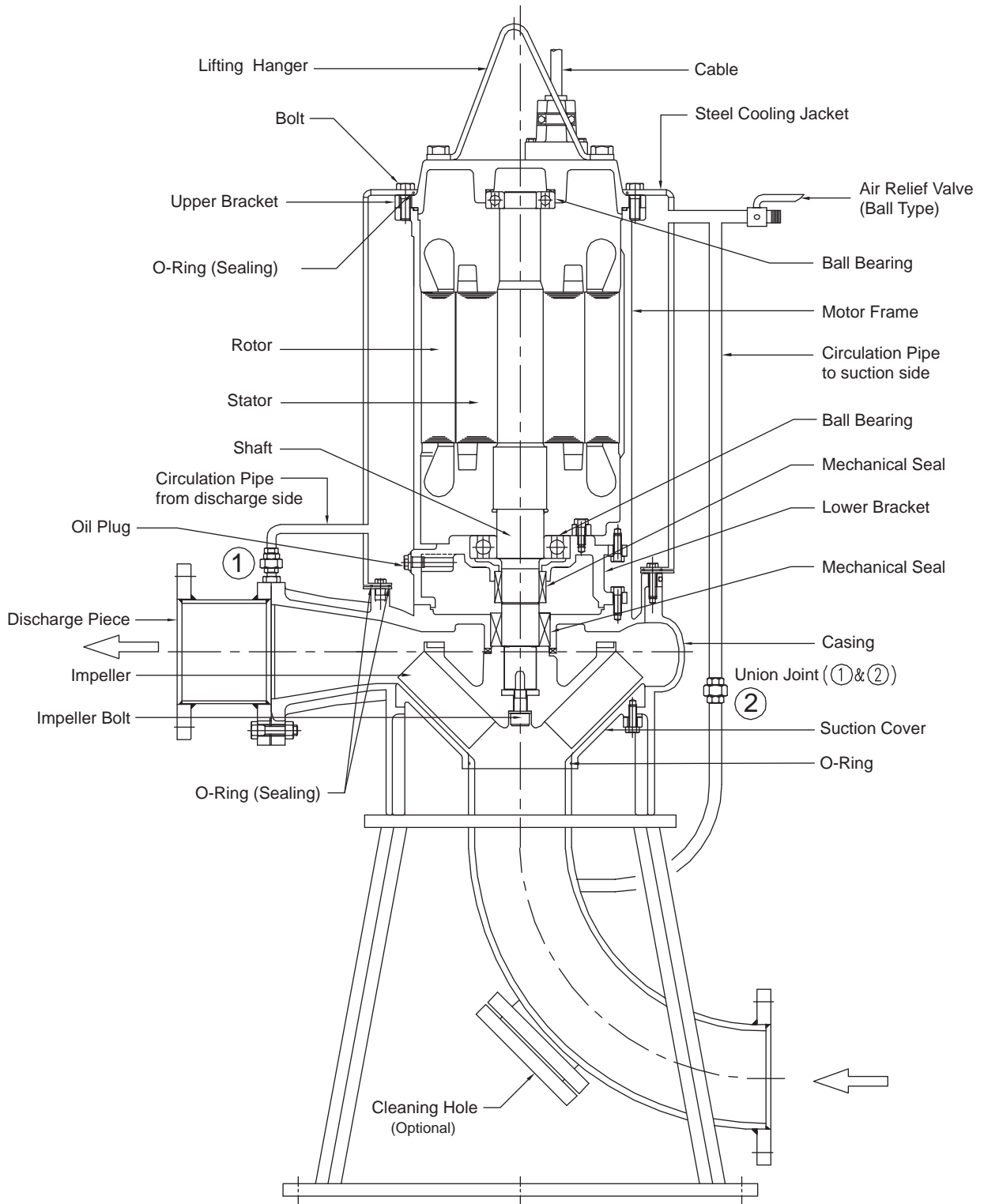

SECTIONAL VIEW VERTICAL DRY PIT

DIMENSION

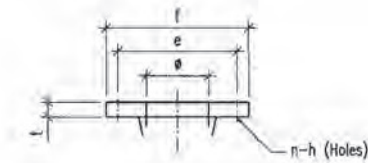
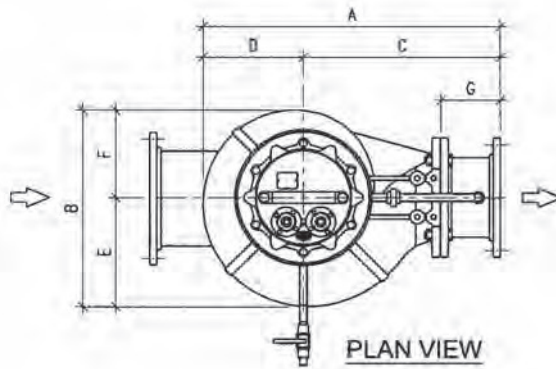

DISCHARGE PIPE FLANGE

Ø2	e	f	t	n	h
150	240	280	22	8	19
200	250	343	24	12	23
250	355	400	30	12	25
300	400	445	32	10	25

SUCTION PIPE FLANGE

Ø1	e	f	t	n	h
200	250	343	29	12	23
300	400	445	34	16	25

* Flange STD : JIS 10K RF

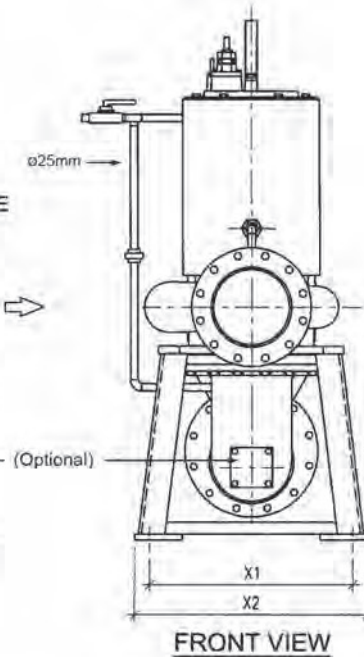
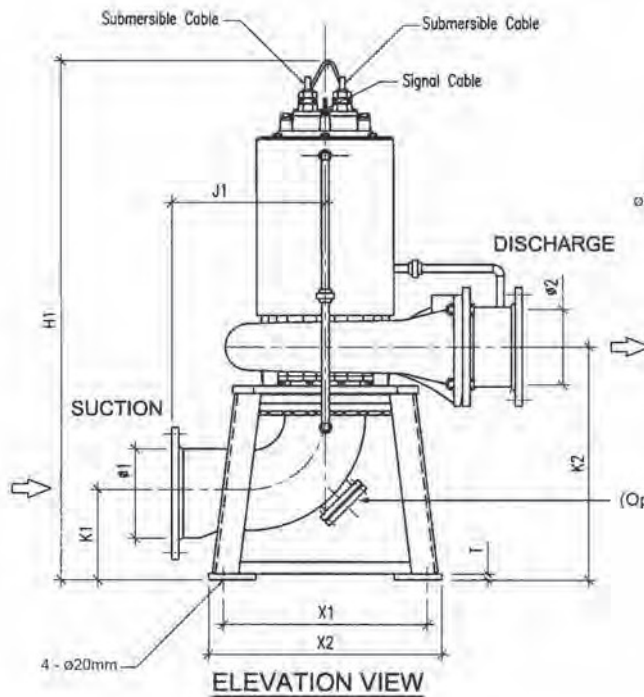

PHASE	Hz	SIZE DA		MODEL	OUTPUT KW	PUMP & MOTOR DIMENSION													
		Ø1	Ø2			A	B	C	D	E	F	G	H1	J1	K1	K2	T	X1	X2
3	50	150	200	200 x 150 DDL530	30	772	520	510	262	283	238	150	1676	320	250	700	9	580	640
				200 x 150 DDL537	37	772	520	510	262	283	238	150	1796	320	250	700	9	580	640
				200 x 150 DDL545	45	772	520	510	262	283	238	150	1796	320	250	700	9	580	640
		200	200	200 x 200 DDL530	30	772	520	510	262	283	238	150	1676	320	250	700	9	580	640
				200 x 200 DDL537	37	772	520	510	262	283	238	150	1796	320	250	700	9	580	640
				200 x 200 DDL545	45	772	520	510	262	283	238	150	1796	320	250	700	9	580	640
	300	250	300	300 x 250 DDL530	30	995	660	660	335	368	293	200	1745	510	300	785	9	630	680
				300 x 250 DDL537	37	995	660	660	335	368	293	200	1884	510	300	785	9	630	680
				300 x 250 DDL545	45	995	660	660	335	368	293	200	1884	510	300	785	9	630	680
		300	300	300 x 300 DDL530	30	1105	660	770	335	368	293	200	1745	510	300	785	9	630	680
				300 x 300 DDL537	37	1105	660	770	335	368	293	200	1884	510	300	785	9	630	680
				300 x 300 DDL545	45	1105	660	770	335	368	293	200	1884	510	300	785	9	630	680

* Dimensional details are provided for reference only.

* All specifications are subject to change without prior notice.



EBARA Pumps Malaysia Sdn Bhd
 6, Jalan TP3, UEP Subang Jaya Industrial Park,
 47620 Subang Jaya, Selangor, Malaysia.
 Tel : 03-8023 6622 Fax : 03-8023 9355
 Email : sales@ebara.com.my
 Website : www.ebara.com.my



Certificate No. KLR 0500080
 Certificate No. KLR 6027651

Authorised dealer: